

# PITELUMEC

## *Thumper 100* DOWN THE HOLE HAMMER



**THUMPER 100 FOR HOLE DIAMETER 254 - 305MM**

# PNEUMEC THUMPER 100 10" DOWN THE HOLE HAMMER

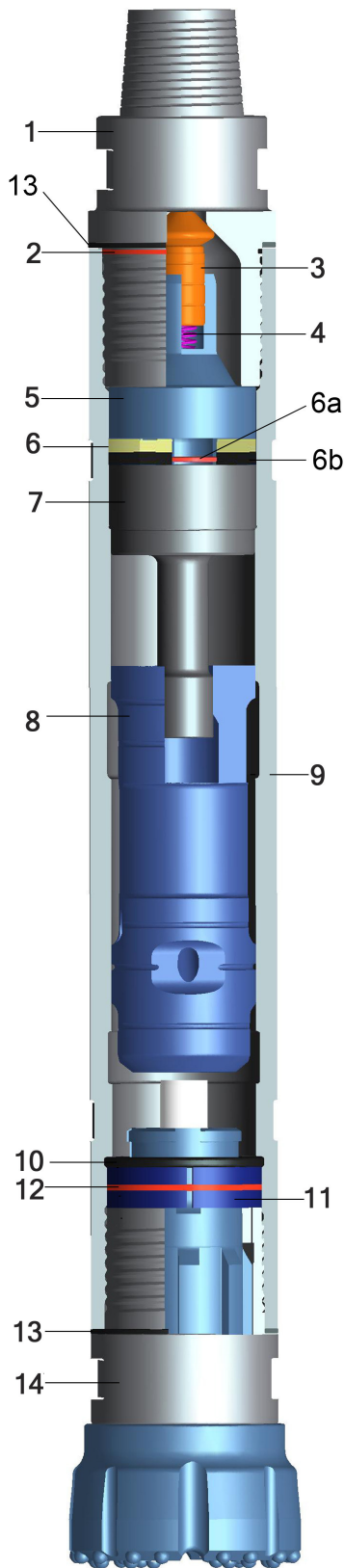

## THUMPER 100 HAMMER PARTS LIST

1.	BACKHEAD 6-5/8" API REG PIN	HSP10S1T5M
2.	BACKHEAD "O" RING	HSP10S2
3.	CHECKVALVE	HSP10S3
4.	CHECK VALVE SPRING	HSP10S4
5.	VALVE CHEST	HSP10S5
6.	MAKE UP RING	HSP10S22
6a.	MAKE UP PLATE "O" RING	HSP10S6
6b.	MAKE UP PLATE	HSP10S23
7.	CONTROL TUBE	HSP10S8
8.	PISTON	HSP10S12S10
9.	WEARSLEEVE	HSP10S18
10.	PISTON RING	HSP10S25
11.	BIT RETAINERS	HSP10S15S10
12.	BIT RETAINER "O" RING	HSP10S16
13.	WASHER (2)	HSP10S21
14.	CHUCK SD10	HSP10S19S10
15.	COMPLETE HAMMER SD10	HAM10SS10THP

## THUMPER 100 HAMMER SPECIFICATIONS

DIAMETER	225MM
LENGTH	1565MM
PISTON WEIGHT	69KG
HAMMER WEIGHT	330KG
HOLE DIAMETER	254MM – 305MM
BACKHEAD CONNECTION	6-5/8" API REG PIN
SHANK TYPE	SD10

## THUMPER 100 HAMMER AIR CONSUMPTION

PRESSURE (BAR / PSI)	CFM	M <sup>3</sup> /MIN
10.3 / 150	711	20
13.8 / 200	1067	30
17.2 / 250	1422	40
24.1 / 350	--	--

# PNEUMEC

**PNEUMEC COMPANY LIMITED**

1st Floor, Tin On Sing Comm. Bldg., 41-43 Graham St. Central, H.K.

Tel : (852) 2180 9922

Fax : (852) 2180 9982

Website : [www.pneumec.com](http://www.pneumec.com)

email : [info@pneumec.com](mailto:info@pneumec.com)